

IPE 303 Product Design I

Product Development Process

R. M. SHAHBAB
Lecturer, Department of IPE, BUET
Email: sshahbab@ipe.buet.ac.bd

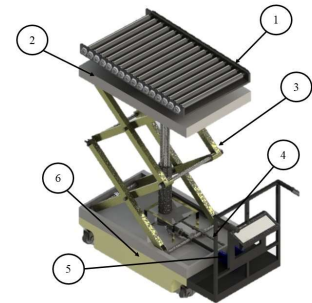

1

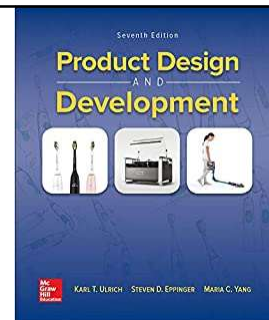

Reference



Chapter 2 - Product Design and Development by Karl T. Ulrich, Steven D. Eppinger, Maria C. Yang, 7th Edition

2

The Product Development Process

- A *process* is a sequence of steps that transforms a set of inputs into a set of outputs (e.g. physical processes used to bake a cake or to assemble an automobile).
- A *product development process* is the sequence of steps or activities that an enterprise employs to plan/conceive, design, and commercialize a product.

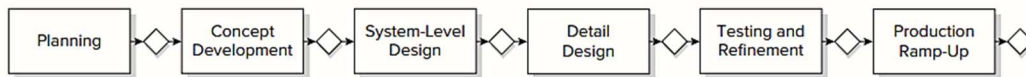

Figure: Generic product development process

3

3

The Product Development Process

A product development process can be visualized in 3 ways:

1. It is the initial creation of a wide set of alternative product concepts and then the subsequent narrowing of alternatives and increasing specification of the product until the product can be reliably and repeatably produced by the production system.



4

4

The Product Development Process

A product development process can be visualized in 3 ways:
(continued)

2. It is an information-processing system. The process begins with inputs such as the *corporate objectives*, *strategic opportunities*, *available technologies*, *product platforms*, and *production systems*.

Various activities process the aforesaid development information to formulate the *specifications*, *concepts*, and *design details*.

The process concludes when all the information required to support production and sales has been created and communicated.

5

5

The Product Development Process

A product development process can be visualized in 3 ways:
(continued)

3. It is a risk management system. In the early phases of product development, various risks are identified and prioritized.

As the process progresses, risks are reduced as the key uncertainties are eliminated and the performance of the product is validated.

When the process is completed, the team should have substantial confidence that the product will work correctly and be successful in the market.

6

6

The Product Development Process

A **well-defined** development process is useful for the following reasons:

1. Quality assurance
2. Coordination
3. Planning and Scheduling
4. Management
5. Improvement

7

7

The Product Development Process

The six phases of the generic development process are:

- | | |
|------------------------|---------------------------|
| 0. Planning | 3. Detail Design |
| 1. Concept Development | 4. Testing and Refinement |
| 2. System-Level Design | 5. Production Ramp-Up |

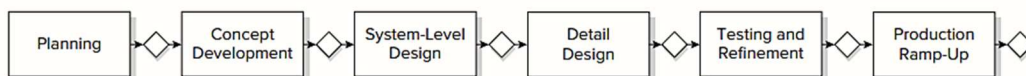

Figure: Generic product development process

8

8

The Product Development Process

The six phases of the generic development:

0. Planning:

- It is often referred to as “*phase zero*” because it precedes the project approval and launch of the actual product development process
- This phase begins with opportunity identification guided by corporate strategy, and includes assessment of technology developments and market objectives

9

9

The Product Development Process

The six phases of the generic development:

0. Planning:

- The output of the planning phase is the **project mission statement**, which specifies:
 - the target market for the product
 - business goals
 - key assumptions
 - constraints

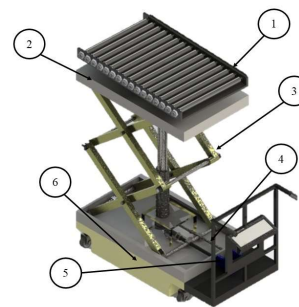

Items	Designation
1	Roller Conveyor
2	Top Platform
3	Scissor Arm
4	Power Screw
5	Synchronized motor
6	Base Platform

10

10

The Product Development Process

The six phases of the generic development:

1. Concept Development:

- In this phase:
 - i. the needs of the target market are identified
 - ii. alternative product concepts are generated and evaluated
 - iii. one or more concepts are selected for further development and testing

11

11

The Product Development Process

The six phases of the generic development:

2. System-level design:

- In this phase:
 - i. the product architecture is defined
 - ii. the product is decomposed into subsystems and components
 - iii. preliminary design of key components are prepared
 - iv. detail design responsibilities are allocated to both internal and external resources

12

12

Similarity with “PD I” Sessional

System-level design:

- the product architecture is defined
- the product is decomposed into subsystems and components

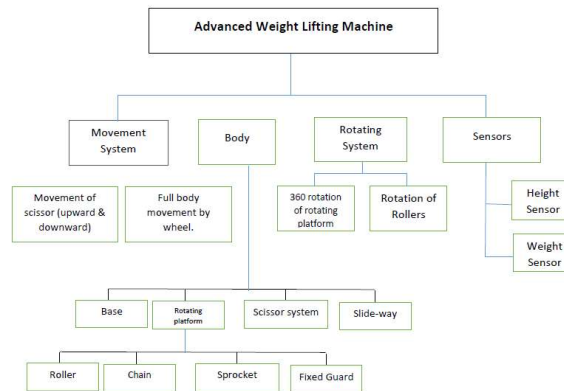

13

13

Similarity with “PD I” Sessional

System-level design:

- preliminary design of key components are prepared
- detail design responsibilities are allocated to both internal and external resources

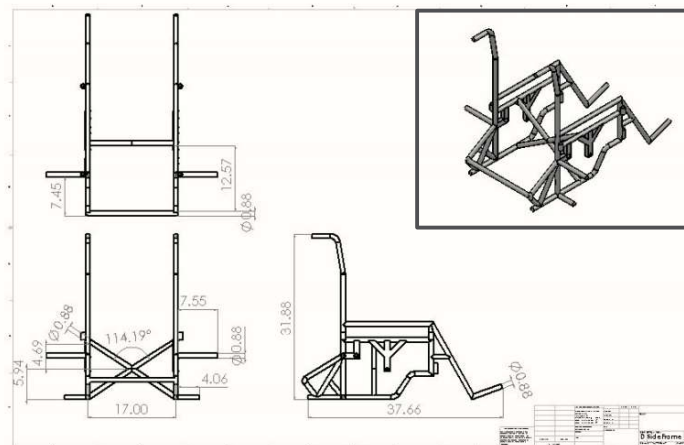

Fig: Main-Frame and its dimension (in inch)

14

14

The Product Development Process

The six phases of the generic development:

2. System-level design:

The output of this phase usually includes:

- a geometric layout of the product

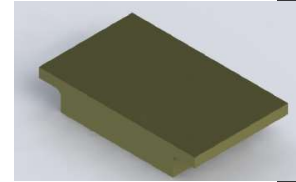

15

15

The Product Development Process

The six phases of the generic development:

2. System-level design:

The output of this phase usually includes:

- a functional specification of each of the product's subsystems

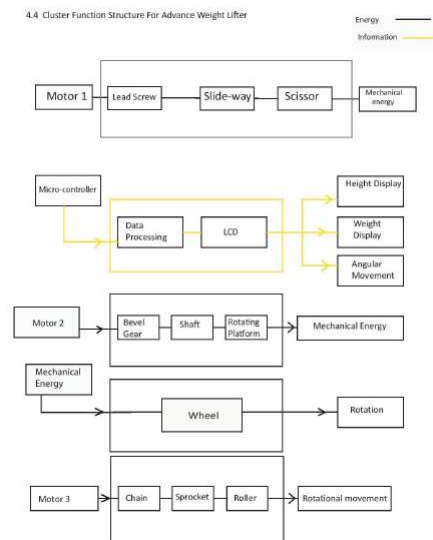

16

16

The Product Development Process

The six phases of the generic development:

2. System-level design:

- The output of this phase usually includes: (continued)
 - iii. a preliminary process flow diagram for the final assembly process.

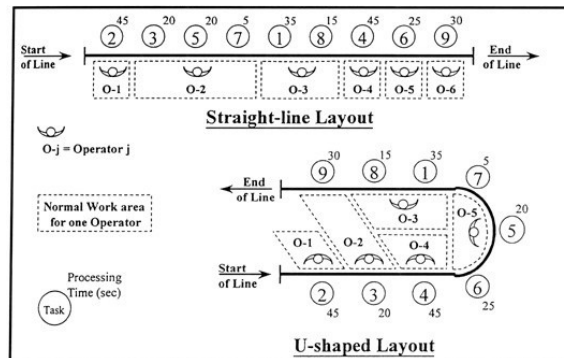

Figure: Typical assembly layouts

17

17

The Product Development Process

The six phases of the generic development:

3. Detail design:

- This phase includes:
 - i. complete specification of the *geometry, materials, and tolerances* of all of the unique parts in the product
 - ii. identification of all of the standard parts to be purchased from suppliers
 - iii. establishment of a process plan*
 - iv. selection of tools for each part to be fabricated *within the production system*

18

18

*Supplementary information from CIM (IPE 419)

PROCESS PLANNING

• Process planning for parts

- For individual parts, the processing sequence is documented on a form called a **route sheet** or **operation sheet**. (Example in next slide)
- It is called a route sheet because the processing sequence defines the route that the part must follow in the factory.
- Just as engineering drawings are used to specify the product design, route sheets are used to specify the process plan. They are counterparts, one for product design, the other for manufacturing.

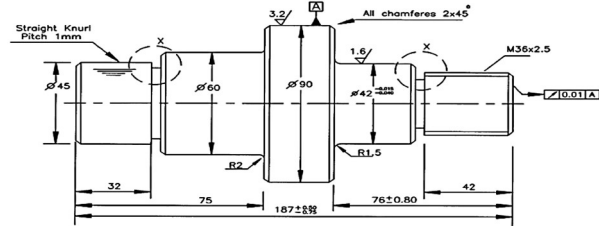

*Supplementary information from CIM (IPE 419)

PROCESS PLANNING

• Typical **Route Sheet** for specifying the process plan

Route Sheet						
XYZ Machine Shop, Inc.						
Part no.	Part name	Planner	Checked by:	Date	Page	
081099	Shaft, generator	MPGroover	N. Needed	08/12/XX	1/1	
Material	Stock size	Comments:				
1050 H18 Al	60 mm diam., 206 mm length					
No.	Operation description	Dept	Machine	Tooling	Setup	Std.
10	Face end (approx. 3 mm). Rough turn to 52.00 mm diam. Finish turn to 50.00 mm diam. Face and turn shoulder to 42.00 mm diam. and 15.00 mm length.	Lathe	L45	G0810	1.0 hr	5.2 min.
20	Reverse end. Face end to 200.00 mm length. Rough turn to 52.00 mm diam. Finish turn to 50.00 mm diam.	Lathe	L45	G0810	0.7 hr	3.0 min.
30	Drill 4 radial holes 7.50 mm diam.	Drill	D09	J555	0.5 hr	3.2 min.
40	Mill 6.5 mm deep x 5.00 mm wide slot.	Mill	M32	F662	0.7 hr	6.2 min.
50	Mill 10.00 mm wide flat, opposite side.	Mill	M13	F630	1.5 hr	4.8 min.

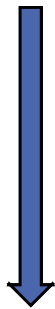

The Product Development Process

The six phases of the generic development:

3. Detail design:

- The output of this phase is the *control documentation* that includes:
 - i. the *drawings* or *computer files* describing the geometry of each part and its production tooling
 - ii. the specifications of the purchased parts
 - iii. the production supply chain
 - iv. the process plans for the *fabrication* and *assembly* of the product

21

21

The Product Development Process

The six phases of the generic development:

3. Detail design:

- *Three* critical issues are finalized in this phase:
 - i. materials selection
 - ii. production cost
 - iii. robust performance

22

22

Similarity with “PD I” Sessional

Detail design:

The drawings or computer files describing the geometry of each part and its production tooling

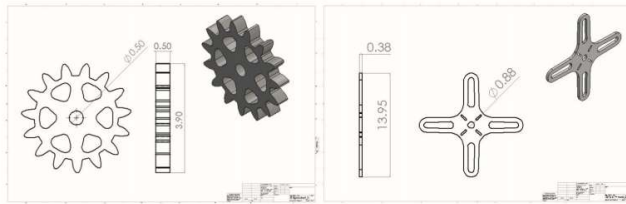

Fig: Sprocket and its dimension (in inch)

Fig: Step wheel and its dimension (in inch)

Route Sheet						
XYZ Machine Shop, Inc.						
Part no.	Part name	Planner	Checked by:	Date	Page	
081099	Shaft, generator	MPGroover	N. Needed	08/12/XX	1/1	
Material	Stock size	Comments:				
1050 Ft18 Al	60 mm diam., 206 mm length					
No.	Operation description	Dept	Machine	Tooling	Setup	Std.
10	Face end (approx. 3 mm). Rough turn to 52.00 mm diam. Finish turn to 50.00 mm diam. Face and turn shoulder to 42.00 mm diam. and 15.00 mm length.	Lathe	L45	G0810	1.0 hr	5.2 min.
20	Reverse end. Face end to 200.00 mm length. Rough turn to 52.00 mm diam. Finish turn to 50.00 mm diam.	Lathe	L45	G0810	0.7 hr	3.0 min.
30	Drill 4 radial holes 7.50 mm diam.	Drill	D09	J555	0.5 hr	3.2 min.
40	Mill 6.5 mm deep x 5.00 mm wide slot.	Mill	M32	F662	0.7 hr	6.2 min.
50	Mill 10.00 mm wide flat, opposite side.	Mill	M13	F630	1.5 hr	4.8 min.

Fig: Sample route sheet

Similarity with “PD I” Sessional

Detail design:

Finalization of materials selection

6.3.2 Calculation of performance index

Selection criteria	Weighting Factor, α	Mild Steel		Cast iron		Stainless Steel	
		Scaled Property, β	Weighted Score, $\alpha\beta$	Scaled Property, β	Weighted Score, $\alpha\beta$	Scaled Property, β	Weighted Score, $\alpha\beta$
Cost	0.13	100	13.00	38.46	5.00	20	2.6
Availability	0.2	100	20	80	16	60	12
Ultimate Tensile Strength	0.13	89.13	11.6	39.6	5.15	100	13
Stiffness	0.13	97.6	12.68	48.78	6.34	100	13
Load Bearing Capacity	0.33	92.86	30.64	74.4	24.55	100	33
Density	0.07	91.85	6.43	100	7	89.79	6.2
			94.35		64.04		79.8

Result: Material performance index is greater for Mild Steel. So we should use Mild Steel for Base Platform.

Similarity with “PD I” Sessional

Detail design:

Finalization of robust performance

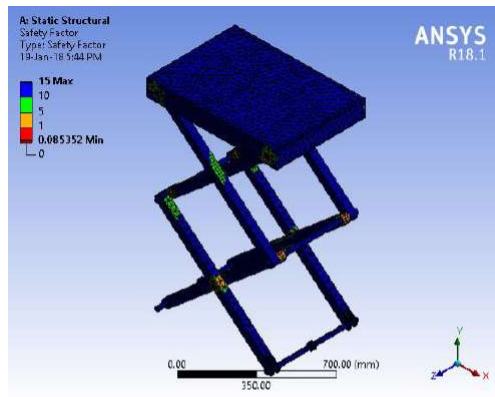

Fig: Safety Factor

25

25

Similarity with “PD I” Sessional

Detail design:

Finalization of production cost

8.5 Break Even Analysis

Fixed cost

- Machine cost = 55,24,000 TK
- Furniture and accessories cost = 2,00,000 TK
- Computer cost: 1,00,000 TK
- Labor cost = 11,76,000Tk
- Fixed manufacturing overhead cost = 1,20,69,600Tk.
- Fixed selling & administrative cost = 21,48,000 Tk.
- Total amount of fixed cost = 2,12,17,600Tk. per year

Variable cost (for the 600 products in the first year)

- Raw material Cost: 3,85,68,600TK
- Purchasing Cost: 1,17,00,000 Tk.

Direct Material Cost Per Year = (3,85,68,600 + 1,17,00,000) TK = 5,02,68,600 TK

Total variable cost per unit production: 5,02,68,600 ÷ 600 = 83,781 TK.

Selling price per unit: 83,781 + 30% of 83,781 = 1,08,985 TK ≈ 1,09,000 TK

26

26

The Product Development Process

The six phases of the generic development:

4. Testing and refinement:

- The testing and refinement phase involves the construction and evaluation of multiple preproduction versions or prototypes of the product.
- Prototypes are usually of two types:
 - i. Early (*alpha*) prototypes
 - ii. Later (*beta*) prototypes

27

27

The Product Development Process

The six phases of the generic development:

4. Testing and refinement:

i. Early (*alpha*) prototypes:

- These are usually built with production-intent parts — parts with the same geometry and material properties as intended for the production version of the product but *not necessarily* fabricated with the *actual processes* to be used in production.
- Alpha prototypes are tested to determine whether the product will work as designed and whether the product satisfies the key customer needs.



28

28

The Product Development Process

The six phases of the generic development:

4. Testing and refinement:

ii. Later (beta) prototypes:

- These are usually built with parts supplied by the intended production processes but **may not be assembled** using the intended final assembly process
- Beta prototypes are extensively evaluated internally and are also typically tested **by customers** in their own use environment
- The goal for the beta prototypes is usually to answer questions about *performance* and *reliability* to identify necessary engineering changes for the final product

29

29

The Product Development Process

The six phases of the generic development:

5. Production ramp-up:

- In the production ramp-up phase, the product is made using the intended production system.
- The purposes of the ramp-up:
 - i. to train the workforce
 - ii. to work out any remaining problems in the production processes

30

30

The Product Development Process

The six phases of the generic development:

5. Production ramp-up:

- Products produced during production ramp-up are sometimes supplied to preferred customers and are carefully evaluated to identify any remaining flaws
- The transition from production ramp-up to ongoing production is usually gradual. At some point in this transition, the product is launched and becomes available for widespread distribution

31

31

The Product Development Process

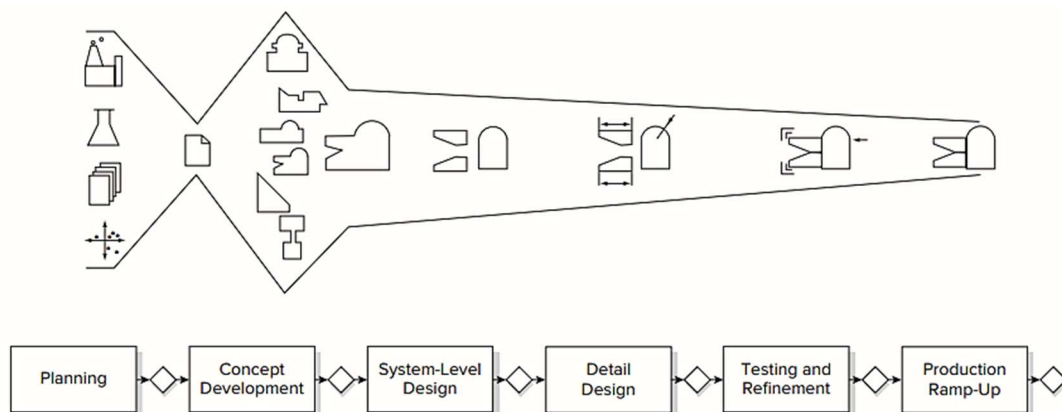

Figure: Illustration of the Generic product development process

32

32

Variants of Generic Product Development Process

- The generic process is most like the process used in a *market-pull* situation: a firm begins product development with a market opportunity and then uses whatever available technologies are required to satisfy the market need (i.e., the market “pulls” the development decisions).

33

33

Variants of Generic Product Development Process

- In addition to the *market-pull* process, several variants are common and correspond to the following:
 1. Technology-push products
 2. Platform products
 3. Process-intensive products
 4. Customized products
 5. High-risk products
 6. Quick-build products
 7. Product-service systems
 8. Complex systems

34

34

Variants of Generic Product Development Process

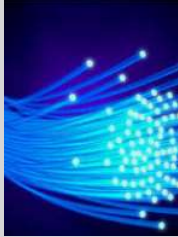
Process Type	Description	Examples
Technology-Push Products	The team begins with a <i>new technology</i> , then finds an <i>appropriate market</i>	Optical fiber 

35

35

Variants of Generic Product Development Process

Process Type	Description	Examples
Platform Products	The team assumes that the <i>new product</i> will be built around an <i>established technological subsystem</i>	Consumer electronics, computers, printers 

36

36

Variants of Generic Product Development Process

Process Type	Description	Examples
<p>Process-Intensive Products</p>	<p><i>Characteristics of the product are highly constrained by the production process</i></p>	<p>Cookies</p> 

37

37

Variants of Generic Product Development Process

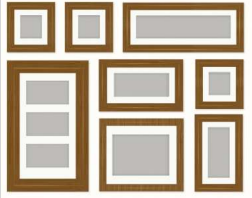
Process Type	Description	Examples
<p>Customized Products</p>	<p>New products are <i>slight variations</i> of existing configurations</p>	<p>Photo frames</p> 

38

38

Variants of Generic Product Development Process

Process Type	Description	Examples
High-Risk Products	<i>Technical</i> or <i>market</i> uncertainties create high risks of failure	Pharmaceuticals 

39

39

Variants of Generic Product Development Process

Process Type	Description	Examples
Quick-Build Products	Rapid modeling and prototyping enables many <i>design-build-test cycles</i>	Clothing 

40

40

Variants of Generic Product Development Process

Process Type	Description	Examples
Digital Products	Following planning and concept development is a highly <i>iterative design-build-test process</i>	Application software 

41

41

Variants of Generic Product Development Process

Process Type	Description	Examples
Product-Service Systems	<i>Products</i> and their <i>associated service</i> elements are developed simultaneously	Restaurants 

42

42

